

APPLICATION

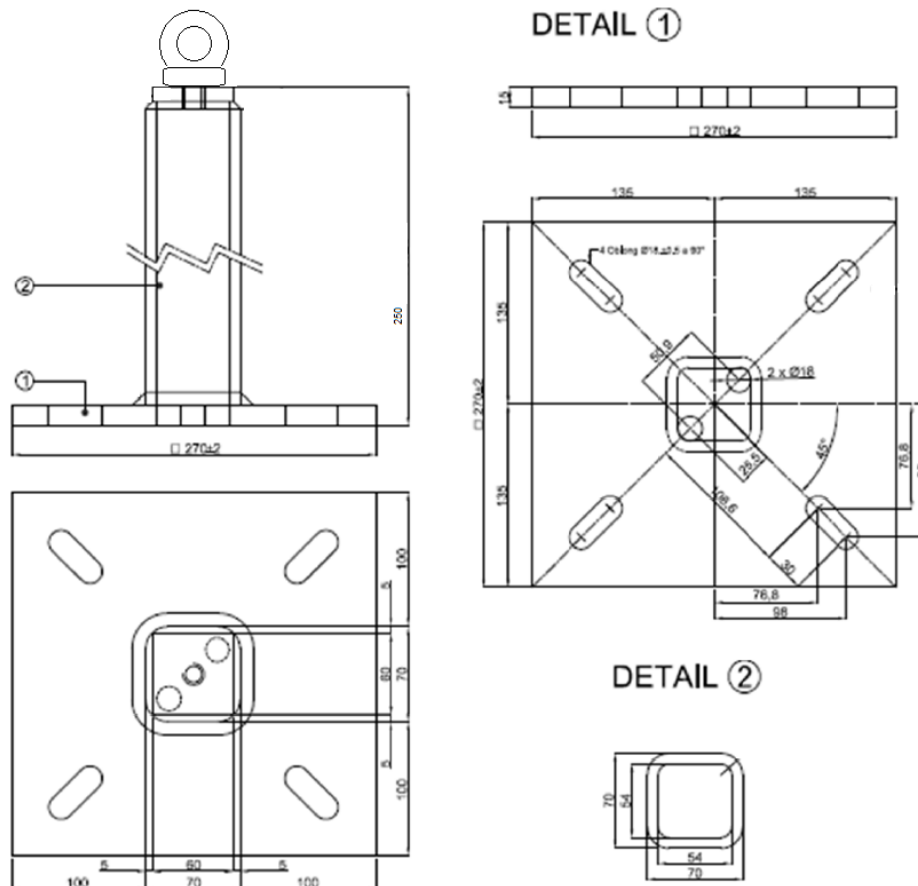



Galvanised anchor post 70x70x250 galva

DESCRIPTION

anneau d'ancrage inox
stainless steel anchor



TECHNICAL CHARACTERISTICS

-  Material: galvanised steel
-  Net weight : 7.2kg
-  1 : base galvanised steel 270x270
-  2 : galvanised tube 70x70x250
-  Stainless steel anchor ring

APPLICABLE STANDARDS

-  EN 795A

COMPOSANTS PRINCIPAUX

| Code | Description | EAN Code | Weight (incl. packaging) | Packaging size |
|-------|-----------------------------|---------------|--------------------------|----------------|
| 72178 | Potelet d'ancrage 70x70x250 | 3600230721781 | 7.2kg | 270x270x250 mm |